

RELAYS, HIGH-SPEED, Nos. 3/401 AND 3/402  
Maintenance

★[NOTE:—As this Instruction has been completely revised, individual paragraphs have not been 'starred'.  
The method of adjusting the relays is now given in more detail]

GENERAL

**1. Introduction.**—This Instruction describes the maintenance and adjustment of Relays, High-speed, Nos. 3/401 and 3/402 which are single-contact high-speed relays. These relays mount in single 3000-type drillings and have one change-over contact unit with single platinum contacts. They supersede the Siemens' Relays Nos. 73 and 85 described in B 5159. Typical relays are shown in Figs. 1 and 2.

**2. Coding.**—The single-coil type is coded 'Relay, High-speed, No. 3/401...', and the double-coil type 'Relay, High-speed, No. 3/402...'. The letters following the code numbers being used to differentiate between individual designs.

**3. Tag numbering.**—The coil and contact connexions are wired to the tag assemblies, as shown in Figs. 3, 4 and 5. The coil connexions are taken to the upper set of tags and the contact connexions to the lower set.

ADJUSTMENT

**4. General.**—

(a) The relays are classified 'red-label' and reference to the appropriate relay-adjustment card is **necessary** before readjustment is made. Relay-adjustment cards may be obtained as described in B 5099. The back of the card should be used for recording test points to enable tests to be made without disconnecting relay wiring.

For guidance in the selection of test points see B 5144.

(b) Adjust the relays in accordance with the methods described in the following paragraphs, and perform the various operations in the sequence in which they are described. If, however, it is required only to adjust the pressure of the break contact, this adjustment may be made independently.

(c) Where adjustment requires the armature to be operated electrically, the specified saturate figure should be used; do not exceed this figure.

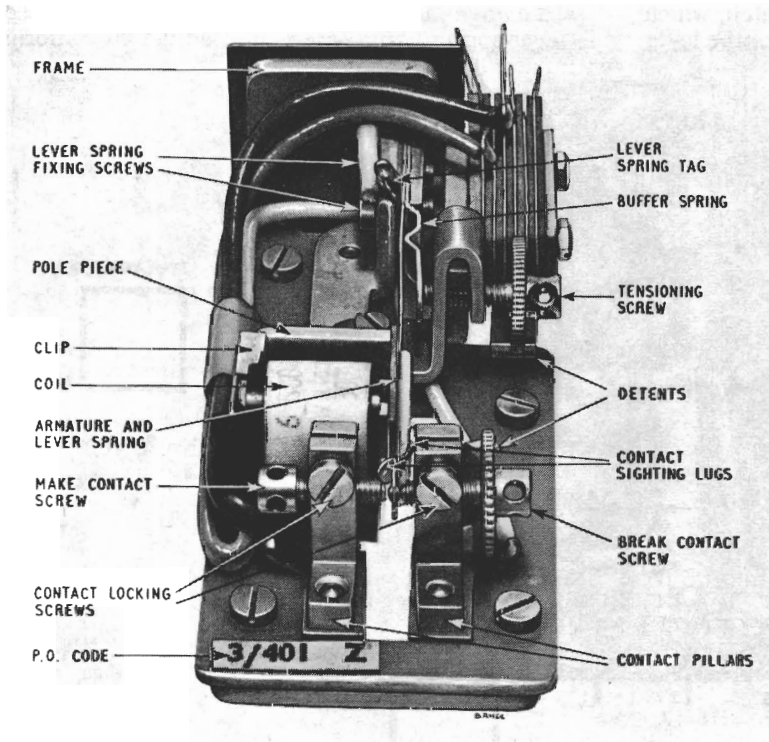

FIG. 1.—RELAY, HIGH-SPEED, No. 3/401

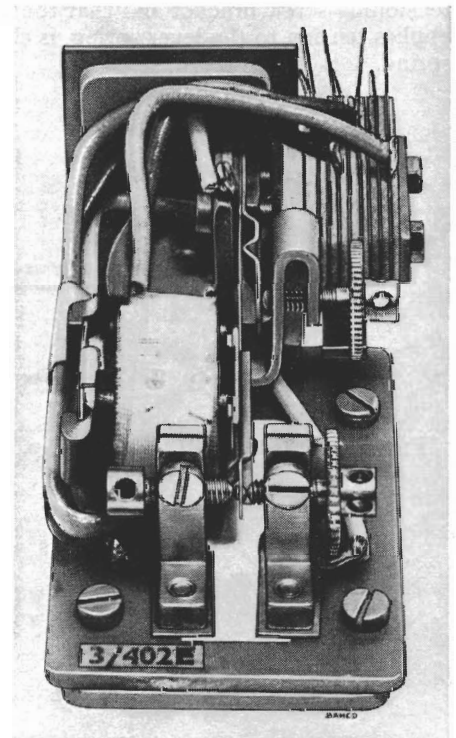

FIG. 2.—RELAY, HIGH-SPEED, No. 3/402

(d) Never loosen the contact-locking screws to the extent that the contact screws become loose in their threads. The contact screws should be a smooth friction fit in the contact pillars when all adjustments are being made. This will prevent any loss in adjustment when the contact-locking screws are finally tightened.

**5. Preliminary work.—**

(a) Disconnect and remove the relay from its mounting.

(b) Change any badly worn or damaged parts, particularly any contact screw or lever spring with badly worn or pitted contacts.

(c) Check that all the baseplate fixing screws are tight.

(d) Check that the coils are firmly secured by the outward tension in the wings of the fixing clip.

(e) If the buffer spring tensioning or break contact screws are knurled and have detent springs against them, check that the tension of the detent spring against the knurled screw is within the range 50-100 gm.

**6. Inspection of spring-set prior to adjustment.—**

(a) *Buffer spring.—*

(i) Withdraw the tensioning screw until it is clear of the buffer spring.

(ii) Check that the buffer spring rests against the tensioning-screw bracket and that the V notch, which applies tension to the lever spring, is clear of the lever spring.

(iii) Check that the V notch is aligned with the lever spring and tensioning screw in such a way that, when the tension is applied, pressure will be evenly exerted across the full width of the lever spring. Where a projection is provided at the centre of the V notch, this projection should be in line with the centre of the lever spring.

(b) *Lever spring.—*

(i) Check that the armature (the rectangular piece of soft iron attached to the lever spring) rests lightly across the whole width of the back edge of the rear pole-face.

(ii) Check that the lever spring is straight from the back edge of the rear pole-face to its root.

(iii) Check that the front end of the lever spring has a 'set' of approximately 2-3° towards the break contact, i.e. from the back end of the armature to the contact. This will normally result in the tip of the lever spring being threequarters of the distance from the left between the two contact pillars (see Fig. 6). This 'set' is important and is to ensure that contact pressure is obtained without undue bowing of the lever spring.

(c) *Contact alignment.—*Check the alignment of the lever-spring contacts with the make and break contacts. These must not be more than one-third of a contact diameter out of alignment.

**7. Lever spring.—**

(a) *To align the contacts and/or buffer spring,* loosen the lever-spring fixing screws and adjust to conform with pars. 6(a) and 6(c).

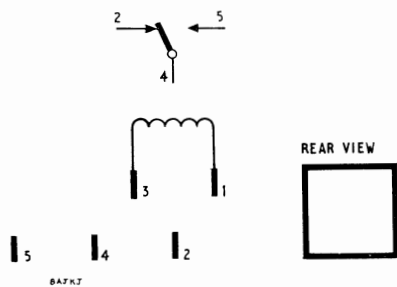

FIG. 3.—SINGLE COIL (RELAY No. 3/401)

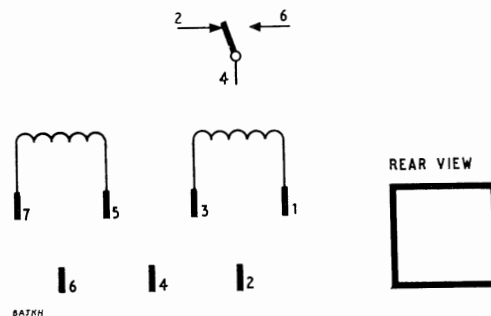

FIG. 4.—DOUBLE COIL (RELAY No. 3/402)

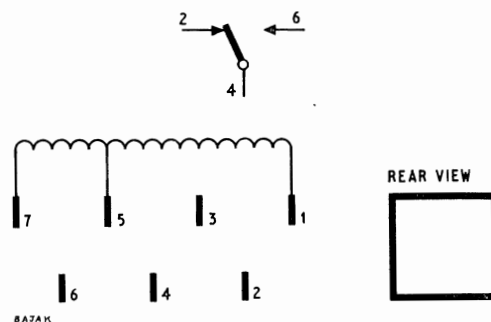

FIG. 5.—TAPPED COIL (RELAY No. 3/401)

(b) To adjust the lever spring other than for alignment.

(i) Remove the lever-spring fixing screws and, using Pliers, Adjusting, No. 1, adjust the lever spring to conform with par. 6(b).

(ii) Re-assemble the lever-spring assembly but, before tightening the fixing screws, adjust the lever and buffer springs until the contacts are in alignment and the buffer spring is in line with the lever spring [see pars. 6(a) and (c)]. Both of these adjustments must be made at the same time because the lever and buffer springs have common fixing screws.

(iii) Tighten the lever-spring fixing screws and re-check the buffer spring and contact alignment.

(c) When the foregoing adjustments have been completed, or if they are not required:—

(i) Loosen the contact-locking screws [see par. 4(d)].

(ii) Withdraw the make and break contacts, until they are well clear of the lever-spring contacts.

**8. Residual gap.**—The residual gap is achieved by making the lever spring contact touch the make contact before the armature touches the front pole-face.

(a) Relays with break-contact ratchet adjustment.—

**NOTE:**—One notch on the periphery of the break-contact screw is equivalent to 0.5 mil of travel of the contact.

(i) Connect an earth to the tag at the root of the lever spring.

(ii) Operate the armature electrically.

(iii) Advance the break contact until it just touches the lever-spring contact. Determine this point electrically by applying a Tester No. 23A to the contact.

(iv) Retract the break-contact screw by the mean residual value. Unless stated otherwise on the relay-adjustment card this value is 4.5 mils (9 notches).

(v) Release the armature.

(vi) Advance the make contact until it just makes contact with the lever-spring contact. Determine this point electrically by applying a Tester No. 23A to the contact.

(vii) Tighten the make-contact locking screw.

(b) Relays without break-contact ratchet adjustment.—

(i) Connect an earth to the tag at the root of the lever spring.

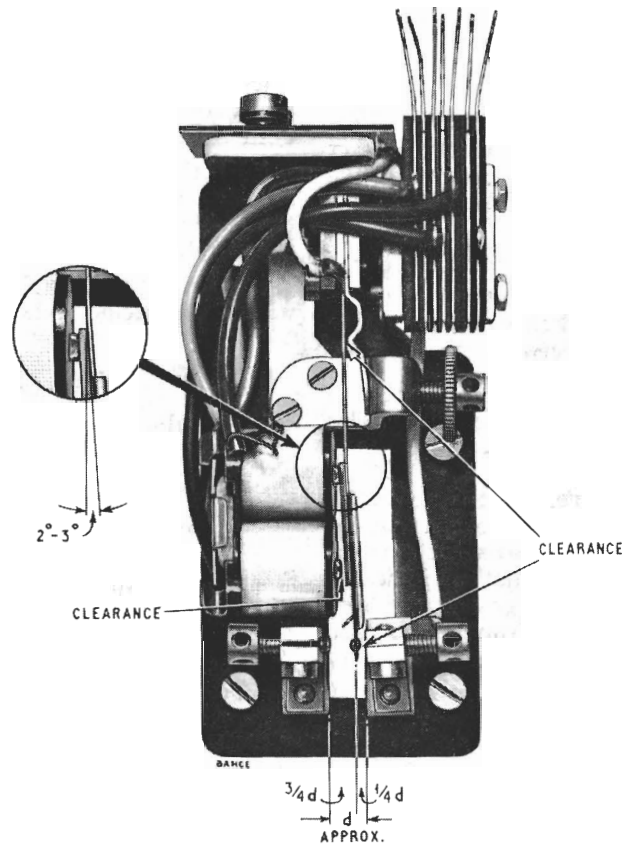

FIG. 6

- (ii) Operate the armature electrically.
- (iii) Advance the make-contact screw until it *just* touches the lever-spring contact. Determine this point electrically by applying a Tester No. 23A to the contact.
- (iv) Insert a feeler gauge of the maximum residual value (5 mils unless stated otherwise on the relay-adjustment card) between the break contact and lever-spring contact and advance the break contact until the gauge is just gripped between the contacts.
- (v) Remove the gauge and check that a gauge one mil smaller will pass freely between the contacts.
- (vi) Release the armature.
- (vii) Advance the make contact until it *just* makes contact with the lever-spring contact. Determine this point electrically by applying a Tester No. 23A to the contact.
- (viii) Tighten the make-contact locking screw.
- (ix) Withdraw the break contact clear of the lever-spring contact.

**9. Contact opening (armature travel).—**

- (a) *Relays with break-contact ratchet adjustment.*—
  - (i) Retract the break-contact screw by the mean value of the contact opening value. Unless stated otherwise on the relay-adjustment card this is 4.5 mils (9 notches).
  - (ii) Tighten the break-contact locking screw.
- (b) *Relays without break-contact ratchet adjustment.*—
  - (i) Insert a feeler gauge of the maximum contact opening value (5 mils unless stated otherwise on the relay-adjustment card) between the make contact and the lever-spring contact.
  - (ii) Advance the break contact, until the gauge is just gripped between the contacts.
  - (iii) Remove the gauge and check that a gauge one mil smaller will pass freely between the contacts.
  - (iv) Tighten the break-contact locking screw.
  - (v) Re-check the contact opening with feeler gauges of the maximum and minimum value.

**10. Break contact pressure.**—With the buffer spring withdrawn from the lever spring, check that the lever spring moves from the break contact when a pressure of 12 gm is applied; if it does not this indicates that the lever spring 'set' is too large and the 'set' should be reduced [see par. 6(b)]. Measure the contact pressures at the tip of the lever spring.

(a) *Relays for which contact pressures are not stated on the relay-adjustment card.*—For these relays a pressure of 12–24 gm should be assumed. Advance the

tensioning screw until the lever spring rests against the break contact with a pressure of 15–21 gm.

(b) *Relays for which contact pressures are stated on the relay-adjustment card.*—Advance the tensioning screw to set the contact pressure towards the mean of the specified values.

Check that the lever spring is not excessively bowed; if it is bowed this indicates that the lever spring 'set' is too small and the 'set' should be increased (see par. 6(b)).

**11. Current tests.—**

*NOTE.*—The use of Clips, Test, No. 32 (see TESTS & INSPECTIONS, General, B 1501) will facilitate connexion to the coil tags for electrical tests.

(a) Check the performance of the relay against the current figures given on the relay-adjustment card. The current tests must be made in the following order:—

- (i) Saturate
- (ii) Hold
- (iii) Release
- (iv) Non-operate
- (v) Operate

(b) If the current figures are met, the relay adjustment is completed.

(c) If the current figures are not met, vary the break contact pressure, within the limits specified, until the required current conditions are satisfied.

(d) If the current figures cannot be met within the specified range of break contact pressure, re-check the residual gap and contact opening, and readjust completely.

(e) If it is not possible to meet the current figures within the specified tolerances, change the relay.

MISCELLANEOUS

**12. Tools.**—The following tools are required for adjusting these relays:—

- Gauges, Feeler, No. 1
- Gauges, Tension, Nos. 1 and 3
- Pliers, Adjusting, No. 1
- Pliers, Adjusting, No. 5
- Screwdriver, Instrument, No. 2
- Spike, Capstan, No. 3B
- Tester No. 23A

**13. Replacement parts.**—See B 5512.

References:—B 5099, B 5144, B 5159, B 5512  
(TPM2/3) TESTS & INSPECTIONS, General, B 1501

E N D